

■ BASIC OF MPX (MULTIPLEX COMMUNICATION)

1. General

In the conventional system, parallel communication is used to exchange information between ECUs. To transmit four pieces of information, for example, parallel communication requires four communication wires. In contrast, multiplex communication is used on serial communication, which converts multiple pieces of information into serial communication data. Thus, they can be transmitted through a single communication wire.

► Conceptual Drawing ◀

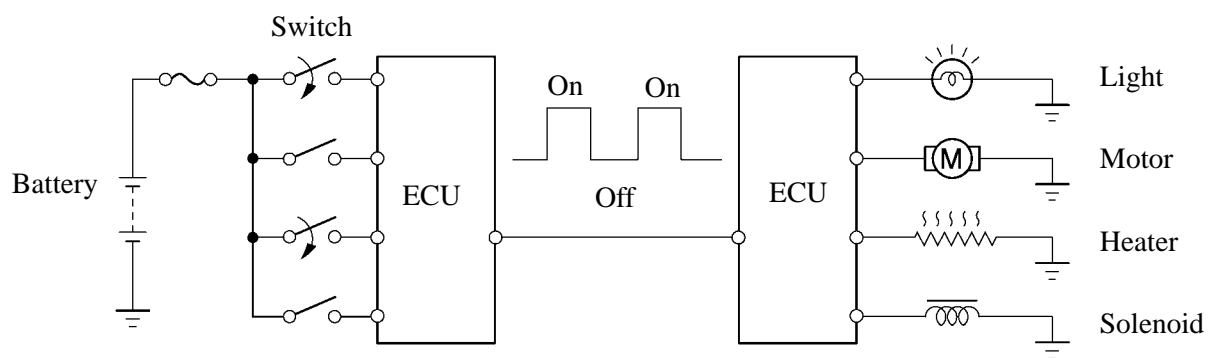

240BE03

Serial Communication

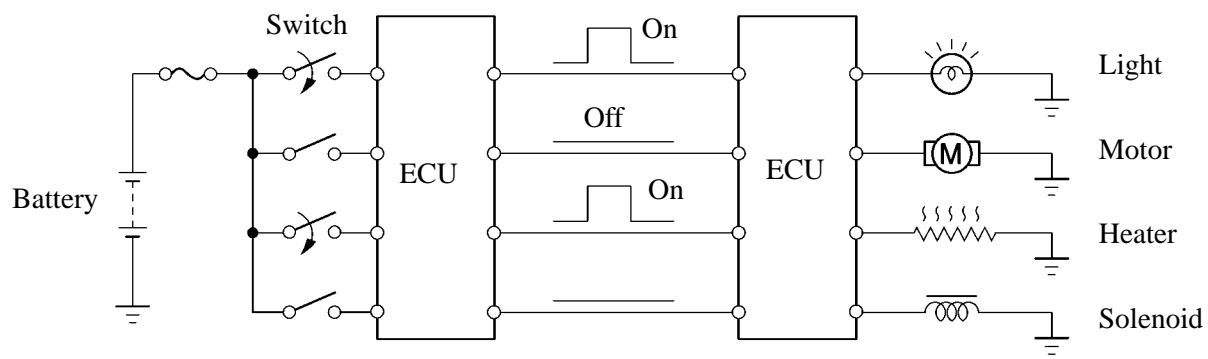

240BE04

Parallel Communication

- Serial communication data consists of bits and frames. A bit is the basic unit that represents the amount of information. A bit is represented by binary values “0” or “1”. A frame is a body of data that is transmitted together. A frame contains a header that indicates the beginning, and an end message that indicates the end.

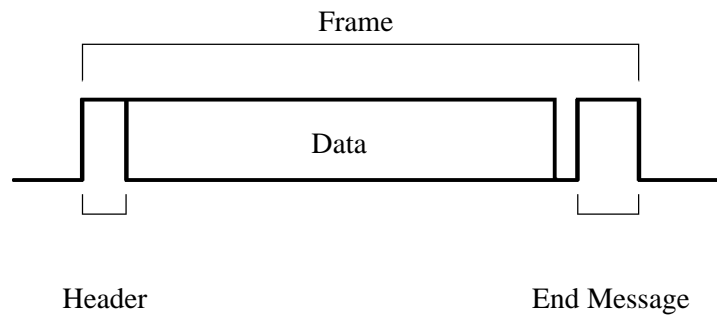

240BE05

2. Network Style

General

Based on serial communication, various ECUs are connected on a network to exchange various pieces of information. Such a system is called “Multiplex Communication”. There are three styles of networks: ring, star, and bus.

Ring Style

In this style of network, the ECUs are connected in a ring form. A feature of this style is that a signal that is output by a transmitting ECU circles the ring and returns to its original ECU.

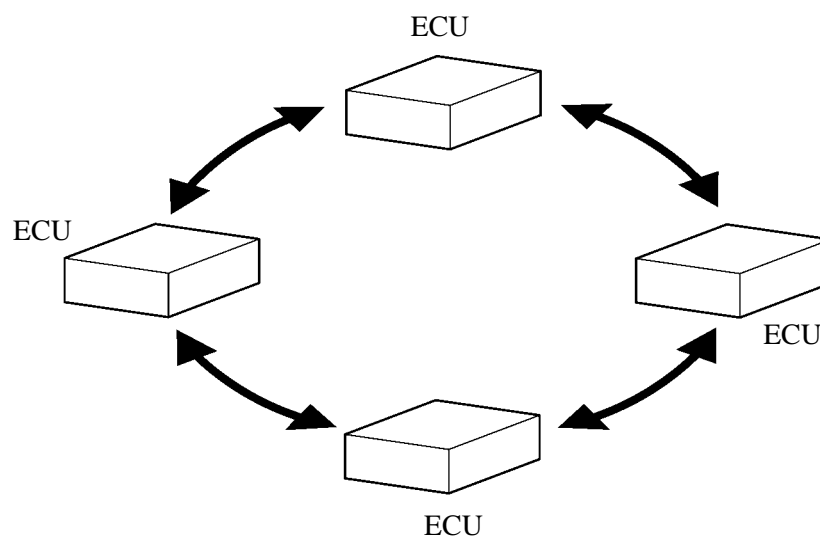

240BE06

Star Style

This style is centered on a master ECU, which holds a central control function. The ECUs are connected in a star shape. The ECUs cannot establish communication with other ECUs without passing through the master ECU.

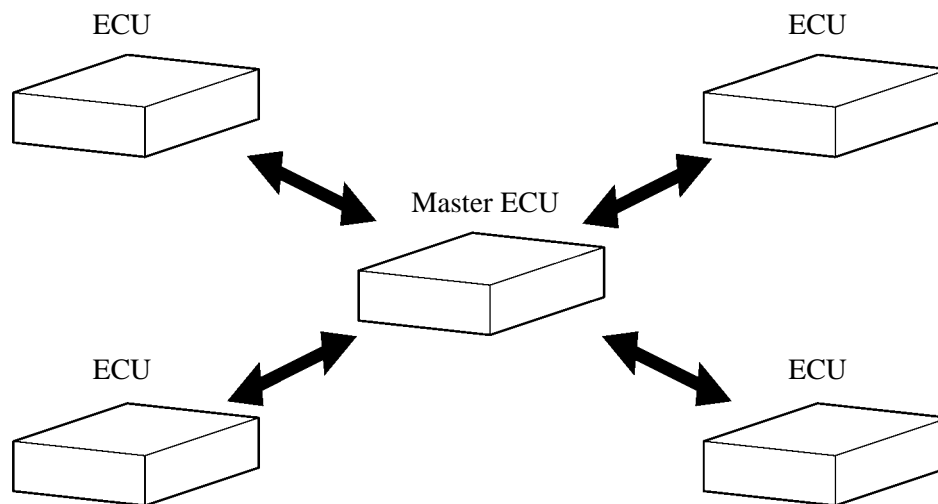

240BE07

Bus Style

In this style of network, all ECUs are connected to a single common communication wire. The transmitting ECUs output signals through a common communication wire and the receiving ECUs input data through a common communication wire.

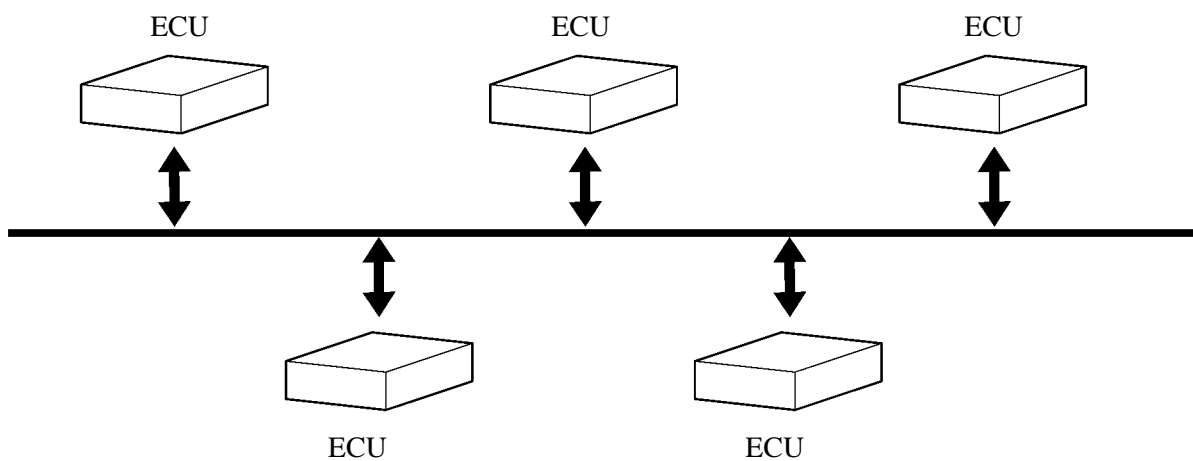

240BE08

— REFERENCE —

- CAN communication on the '04 Prius uses the multi star style bus connection. The two junction connectors are connected with a main bus line. The junction connector extend sub bus line, and enables communication between all the connected ECUs.

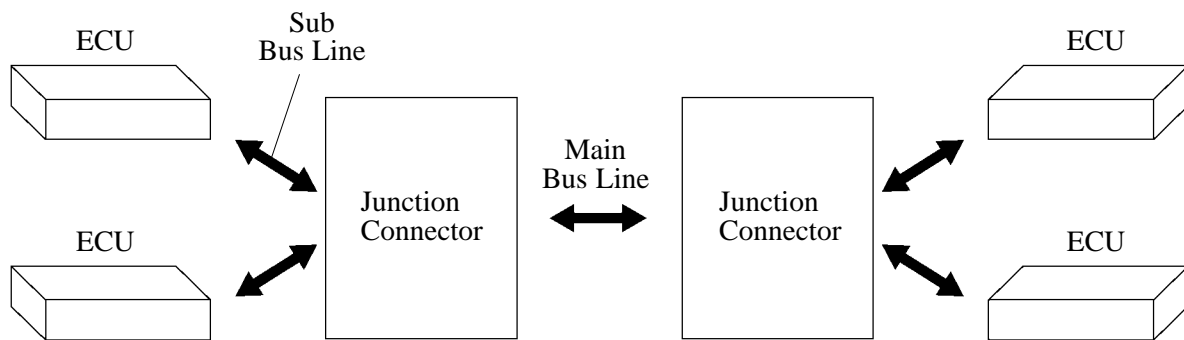

241BE02

- The BEAN on the '04 Prius uses the ring and bus styles of networks to connect ECUs. This style of connection method is called a “Daisy Chain”. In a daisy chain, communication can be maintained even if there is an area that has an open circuit.

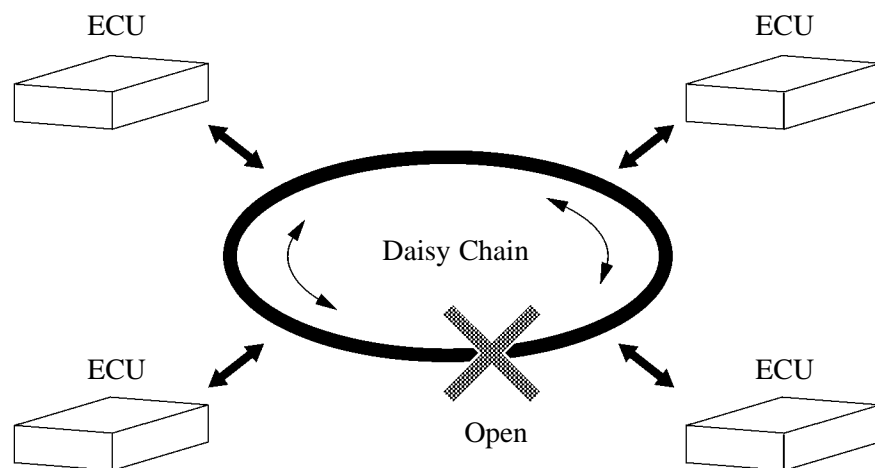

241BE06

- The AVC-LAN in the '04 Prius uses a star style, which is centered on the multi display.

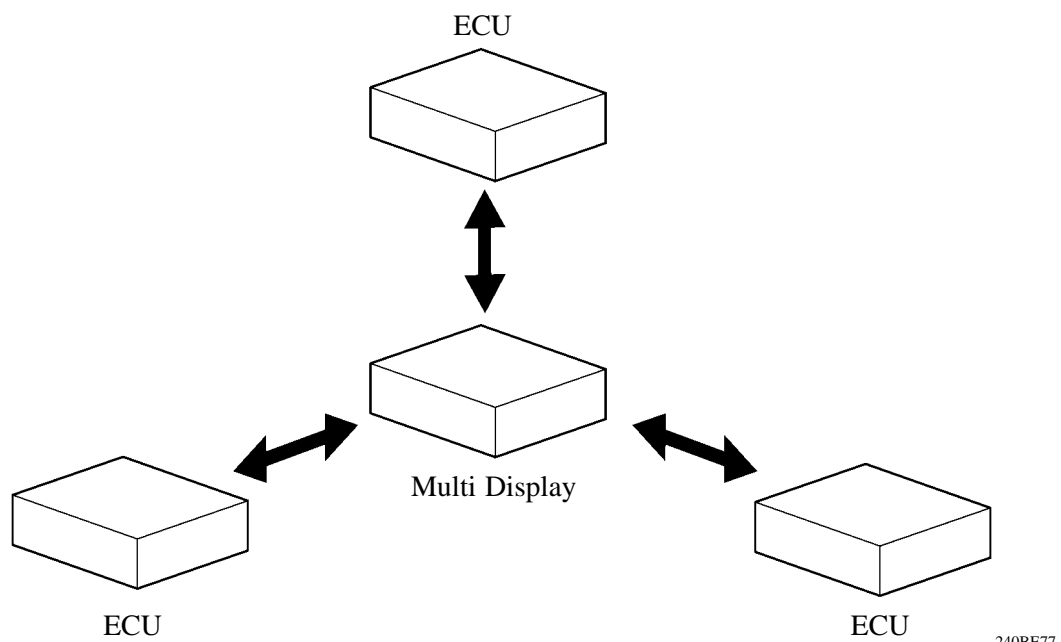

3. Difference of CAN, BEAN and AVC-LAN

- The protocols, which are the rules for establishing data communication, differ between the CAN, BEAN and the AVC-LAN. If ECUs use different types of data such as communication speed, communication wire, and signals, they will be unable to understand each other. Therefore, protocols (rules) must be established among them.

Control	Chassis Electrical System Control		
	CAN (ISO Standard)	Body Electrical System Control	
Protocol	CAN (ISO Standard)	BEAN (TOYOTA Original)	AVC-LAN (TOYOTA Original)
Communication Speed	500 k bps* (Max. 1 M bps)	Max. 10 k bps*	Max. 17.8 k bps*
Communication Wire	Twisted-pair Wire	AV Single Wire	Twisted-pair Wire
Drive Type	Differential Voltage Drive	Single Wire Voltage Drive	Differential Voltage Drive
Data Length	1-8 Byte (Variable)	1-11 Byte (Variable)	0-32 Byte (Variable)

*: bps: abbreviation for “Bits Per Second”, indicating the number of bits that can be transmitted per second.

- Although BEAN and AVC-LAN communicate at almost the same speed, the CAN communication speed is much faster than BEAN or AVC-LAN. When the vehicle control system uses BEAN or AVC-LAN, which have a slower communication speed than CAN, it means that the system control could be delayed by the slow speed. For this reason, the vehicle control system uses CAN, which can send and receive a large volume of data at one time, in addition to being able to transmit at a faster speed.
- The gateway ECU connects the CAN, BEAN, AVC-LAN and the DLC3, and manages the communication among them.

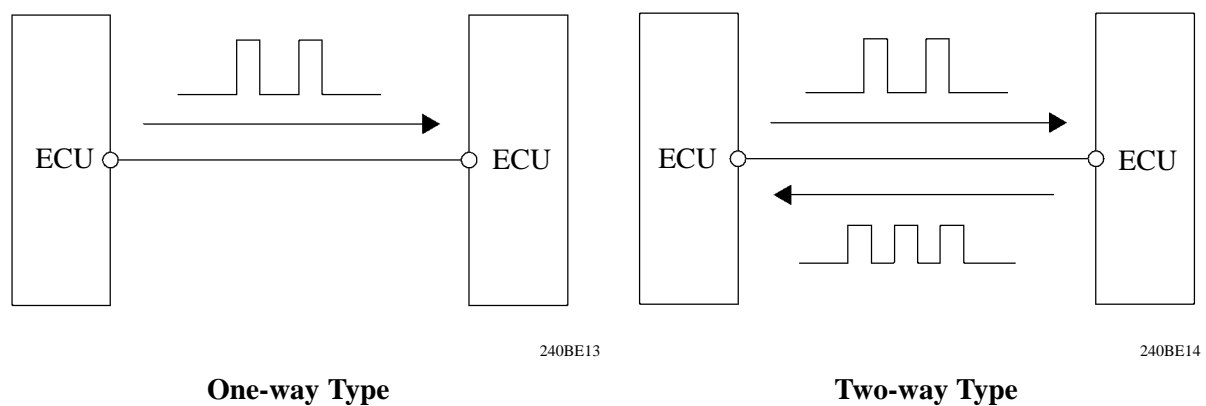

— **REFERENCE** —

There are two types of BEAN communication methods: the one-way type and the two-way type. The '04 Prius uses the two-way type, which is currently in the main stream.

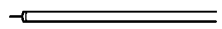

4. Communication Wire

A single, AV (Automobile Vinyl) wire is used for BEAN communication. A twisted-pair wire is used for CAN and AVC-LAN communication.

Communication Wire	Outline
AV Single Wire  240BE09	This is a lightweight single communication wire that consists of a single core line surrounded by insulation. Voltage is applied to this line in order to drive communication, and this system is called a “Single Wire Voltage Drive”.
Twisted-pair Wire for AVC-LAN  240BE10	In this communication wire, a pair of lines is twisted together and covered with insulation. Communication is driven by applying positive (+) and negative (-) voltage to the two lines in order to send a single signal. This system, which is called a “Differential Voltage Drive”, can reduce noise.
Twisted-pair Wire for CAN  241BE168	In this communication wire, a pair of lines is twisted. Communication is driven by applying 1.5 to 2.5 V and 2.5 to 3.5 V of voltage to the two lines in order to send a single signal. This system, which is called a “Differential Voltage Drive”, can reduce noise.

► **Single Wire Voltage Drive** ◄

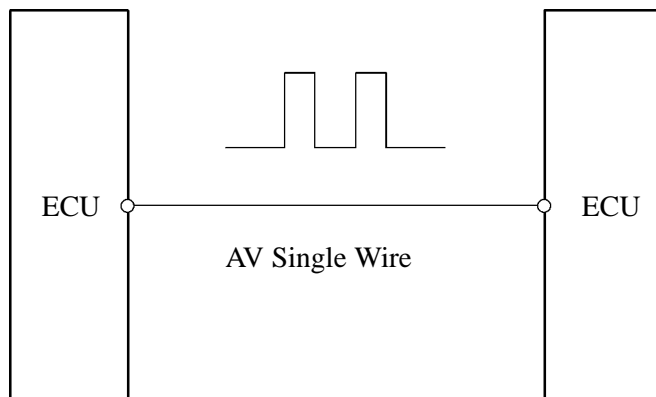

240BE11

► **Differential Voltage Drive** ◄

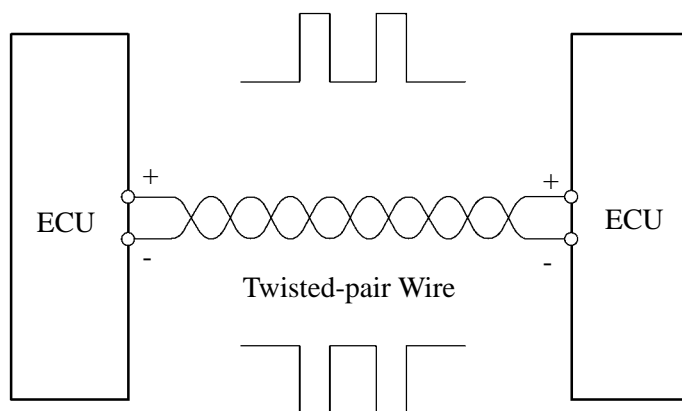

240BE12