

ECU POWER SOURCE CIRCUIT

CIRCUIT DESCRIPTION

This circuit provides power to operate the transponder key ECU assy.

WIRING DIAGRAM

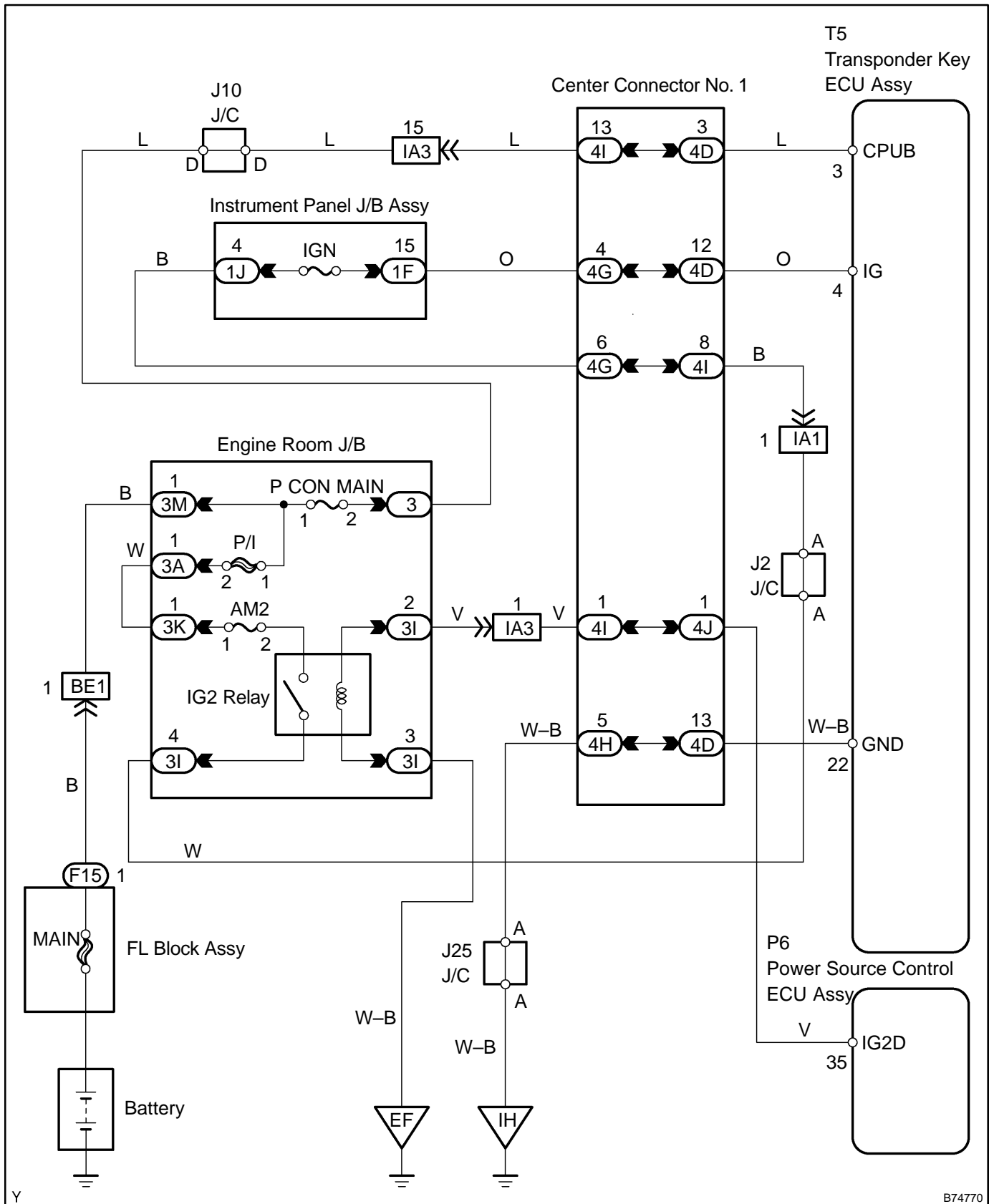

Y

B74770

INSPECTION PROCEDURE

1 INSPECT FUSE (IGN, P CON MAIN, AM2)

- (a) Remove the IGN fuse from the instrument panel J/B Assy.
- (b) Remove the P CON MAIN and AM2 fuses from the engine room J/B.
- (c) Measure the resistance.

Standard: Below 1 Ω

NG → REPLACE FUSE

OK

2 CHECK WIRE HARNESS (TRANSPONDER KEY ECU ASSY – POWER SOURCE CONTROL ECU ASSY AND BODY GROUND)

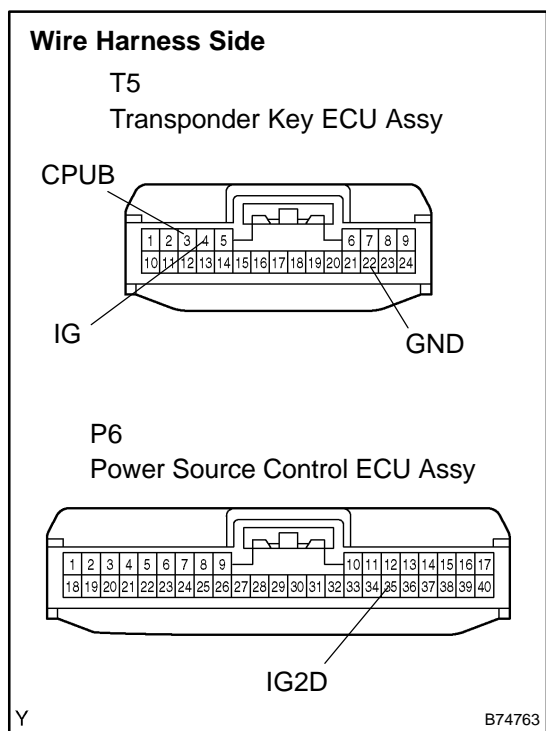

- (a) Disconnect the T5 and P6 ECU connectors.
- (b) Measure the resistance and voltage of the wire harness side connectors.

Standard:

Tester Connection	Condition	Specified Condition
T5-4 (IG) – Body ground	Power switch's power mode OFF → ON (IG)	0 V → 10 to 14 V
P6-35 (IG2D) – Body ground	Constant	Below 1 Ω
T5-3 (CPUB) – Body ground	Constant	10 to 14 V
T5-22 (GND) – Body ground	Constant	Below 1 Ω

NG → REPAIR OR REPLACE WIRE HARNESS AND CONNECTOR

OK

PROCEED TO PUSH BUTTON START SYSTEM (See page 05-2420)

WIRING DIAGRAM

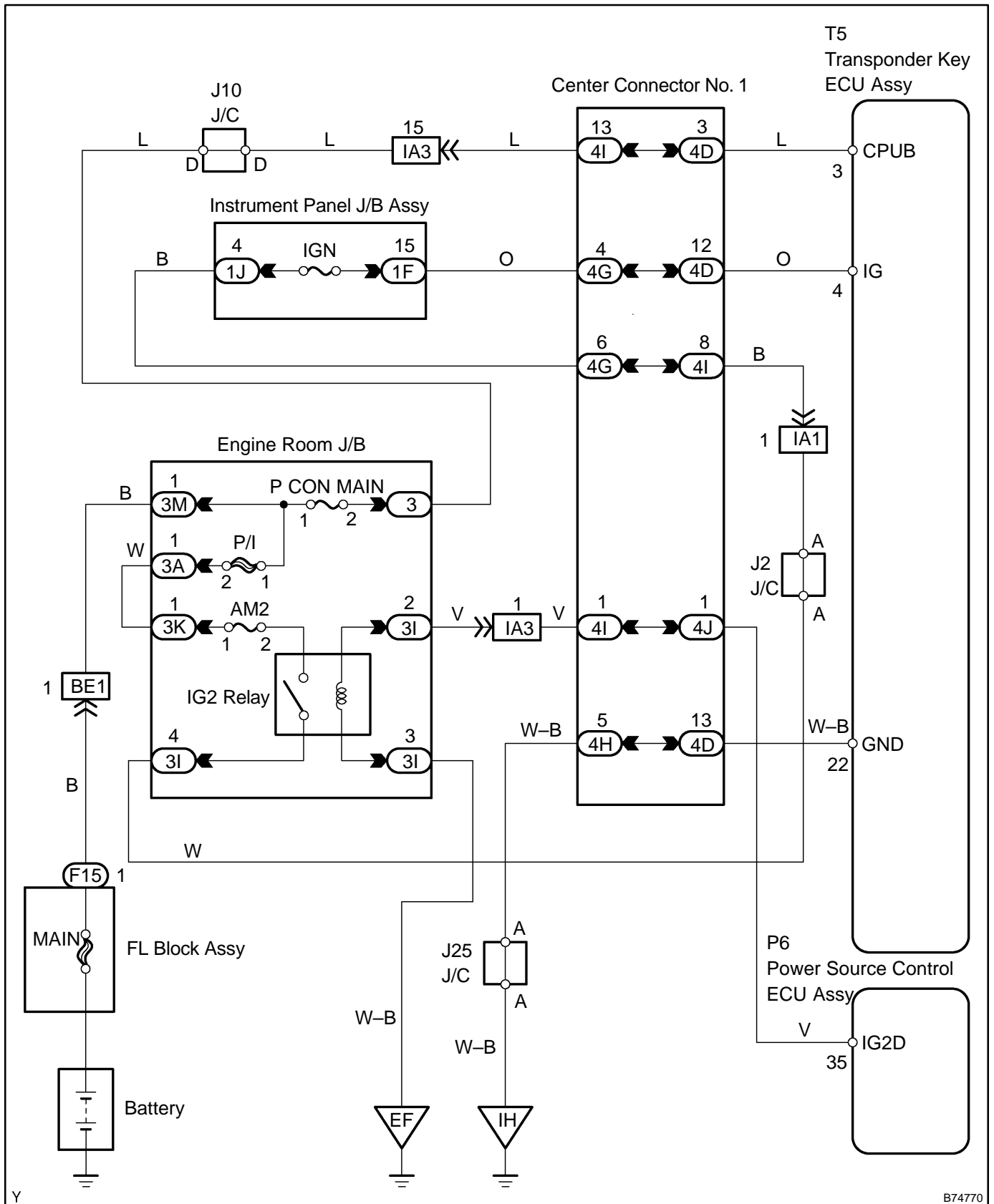

Y

B74770

INSPECTION PROCEDURE

1 INSPECT FUSE (IGN, P CON MAIN, AM2)

- (a) Remove the IGN fuse from the instrument panel J/B Assy.
- (b) Remove the P CON MAIN and AM2 fuses from the engine room J/B.
- (c) Measure the resistance.

Standard: Below 1 Ω

NG → REPLACE FUSE

OK

2 CHECK WIRE HARNESS (TRANSPONDER KEY ECU ASSY – POWER SOURCE CONTROL ECU ASSY AND BODY GROUND)

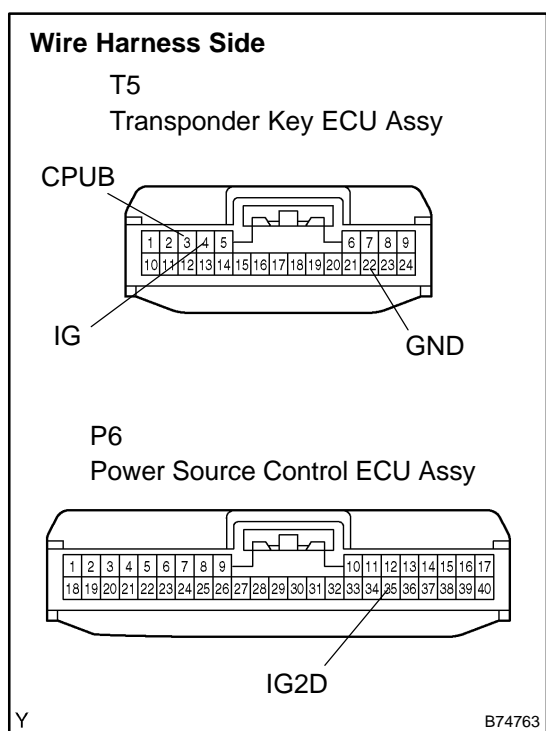

- (a) Disconnect the T5 and P6 ECU connectors.
- (b) Measure the resistance and voltage of the wire harness side connectors.

Standard:

Tester Connection	Condition	Specified Condition
T5-4 (IG) – Body ground	Power switch's power mode OFF → ON (IG)	0 V → 10 to 14 V
P6-35 (IG2D) – Body ground	Constant	Below 1 Ω
T5-3 (CPUB) – Body ground	Constant	10 to 14 V
T5-22 (GND) – Body ground	Constant	Below 1 Ω

NG → REPAIR OR REPLACE WIRE HARNESS AND CONNECTOR

OK

PROCEED TO PUSH BUTTON START SYSTEM (See page 05-2420)